

# Instalime Sanitare

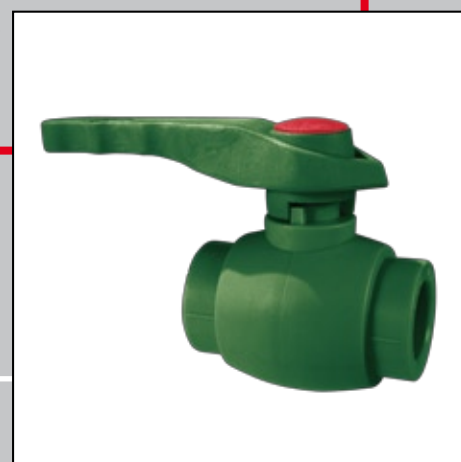

## KATALOG I PRODHIMEVE

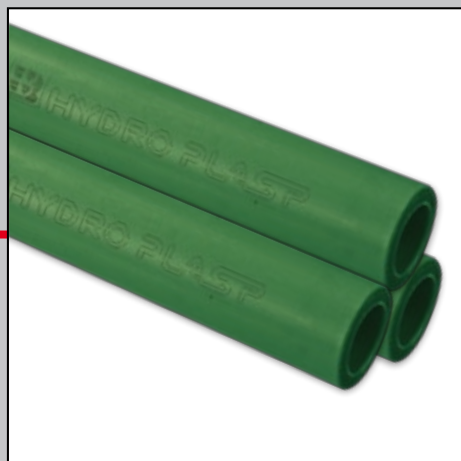

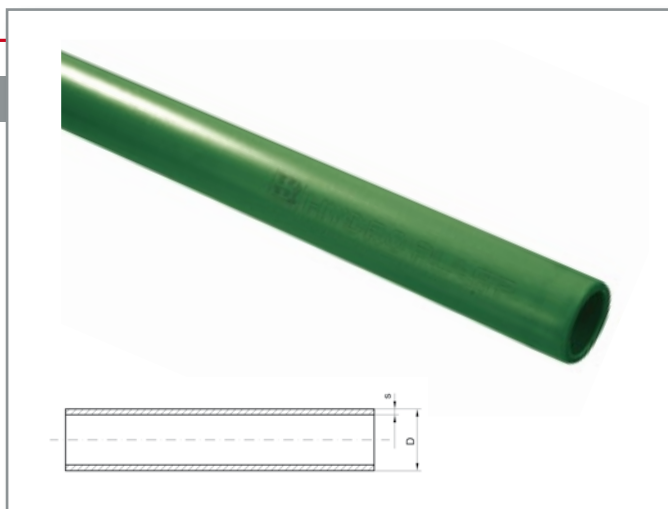

### Tubë SDR 11

Art.no	D	s	kg/lm	lm / pack
G11001	20	1,9	0,107	200
G11002	25	2,3	0,164	160
G11003	32	2,9	0,267	80
G11004	40	3,7	0,412	60
G11005	50	4,6	0,638	40
G11006	63	5,8	1,01	24
G11007	75	6,8	1,42	20
G11008	90	8,2	2,03	12
G11009	110	10,0	3,01	8

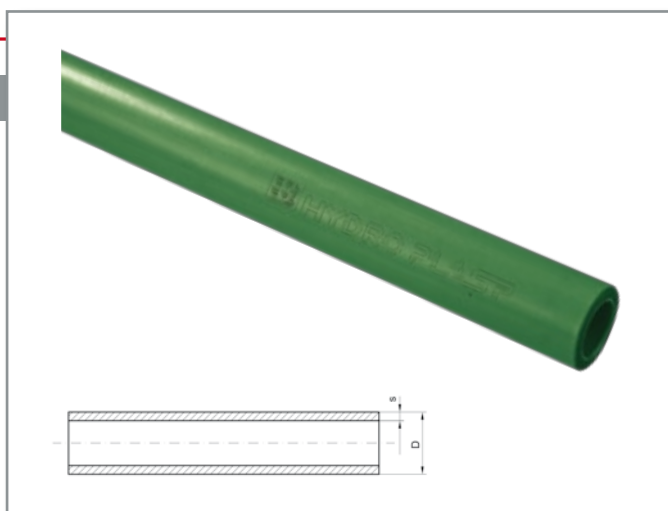

### TUBË SDR 7,4

Art.no	D	s	kg/lm	lm / pack
G11501	20	2,8	0,148	160
G11502	25	3,5	0,230	100
G11503	32	4,4	0,376	60
G11504	40	5,5	0,583	40
G11505	50	6,9	0,894	28
G11506	63	8,6	1,42	16
G11507	75	10,3	2,02	12
G11508	90	12,3	2,91	8
G11509	110	15,1	4,32	4

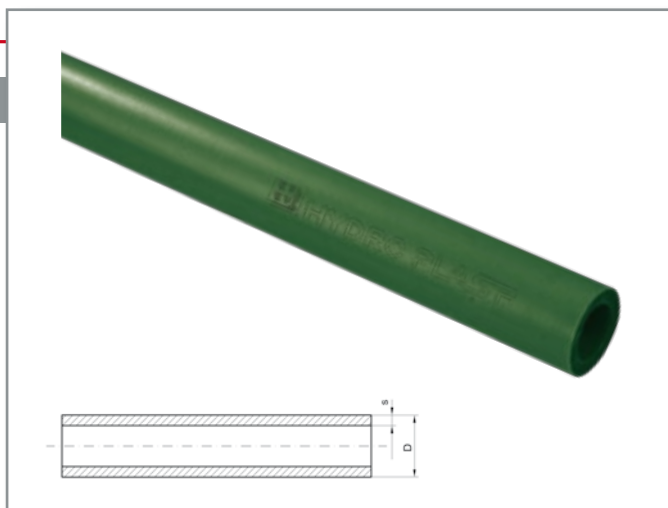

### Tubë SDR 6

Art.no	D	s	kg/lm	lm / pack
G12000	16	2,7	0,110	200
G12001	20	3,4	0,172	160
G12002	25	4,2	0,266	100
G12003	32	5,4	0,434	60
G12004	40	6,7	0,671	40
G12005	50	8,3	1,05	28
G12006	63	10,5	1,65	16
G12007	75	12,5	2,34	12
G12008	90	15,0	3,36	8
G12009	110	18,3	5,04	4

**Tubë SDR 7.4 STABI AL.**

Art.no	D	s	d	Dc	kg/lm	lm / pack
G13501	20	2,8	14,4	21,8	0,194	100
G13502	25	3,5	18	26,9	0,292	80
G13503	32	4,4	23,2	33,9	0,462	40
G13504	40	5,5	29	41,9	0,682	28
G13505	50	6,9	36,2	51,9	1,003	20
G13506	63	8,6	45,8	64,9	1,54	12
G13507	75	10,3	54,4	76,9	2,59	8

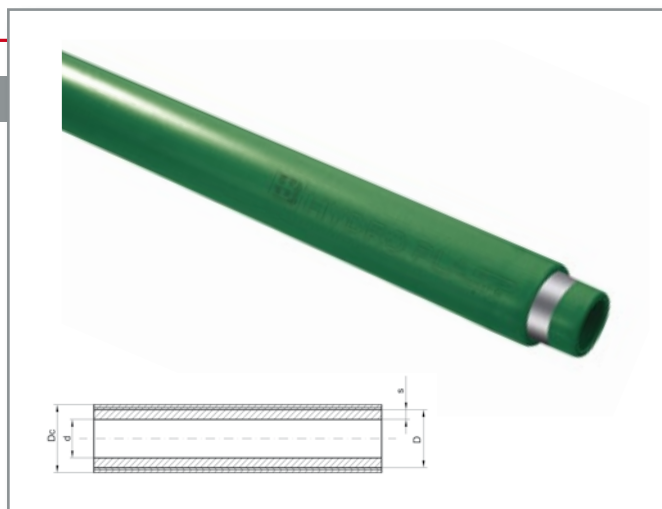

**Tubë SDR 6 STABI AL.**

Art.no	D	s	d	Dc	kg/lm	lm / pack
G13001	16	2,7	10,6	17,8	0,160	160
G13002	20	3,4	13,2	21,8	0,218	100
G13003	25	4,2	16,6	26,9	0,328	80
G13004	32	5,4	21,2	33,9	0,520	40
G13005	40	6,7	26,6	41,9	0,770	28
G13006	50	8,3	33,4	51,9	1,159	20
G13007	63	10,5	42,0	64,9	1,77	12
G13008	75	12,5	50,0	76,9	2,51	8

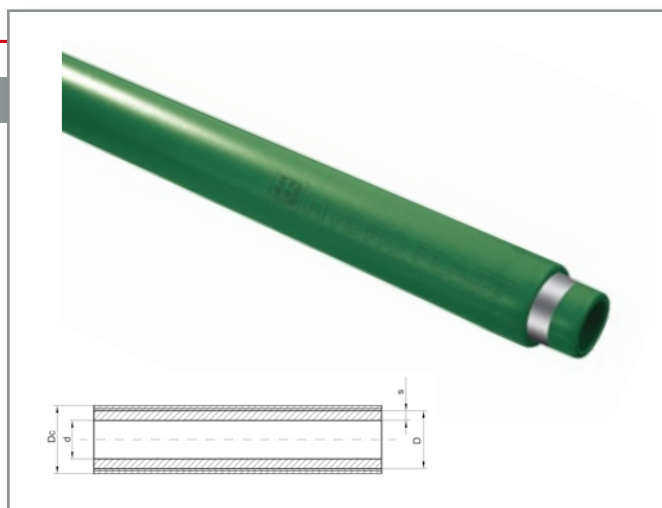

**TUBË STABI**

Tuba Stabi i kombinon avantazhet e tubave prej metalit dhe ato të plastikës.

Nga tubat homogjene dallon në koeficientin linear ekspansionues i cili është:

$\alpha = 0.03$  [mm/mK] - për tubat STABI

$\alpha = 0.15$  [mm/mK] - për tuat homogjene

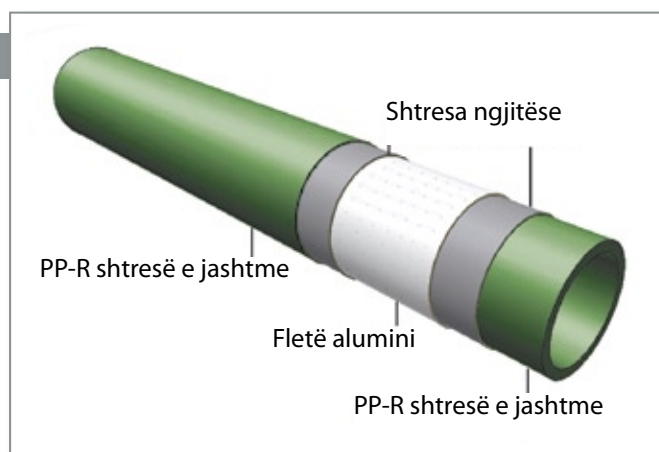

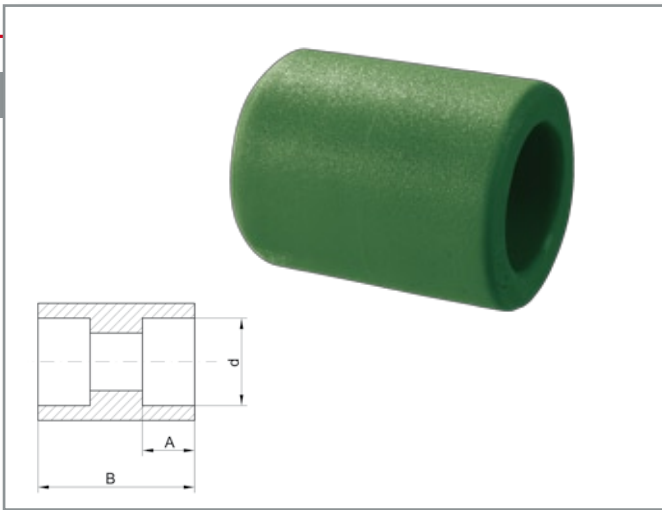

### PRIZË

Art.no	d	A min.	B	Pcs/pack
G30000	16	13,3	35,0	1200
G30001	20	14,5	37,5	700
G30002	25	16,0	40,5	500
G30003	32	18,1	44,5	240
G30004	40	20,5	52,5	120
G30005	50	23,5	56,5	80
G30006	63	27,4	67,0	48
G30007	75	31,0	71,5	44
G30008	90	35,5	86,5	21
G30009	110	41,5	80,0	16

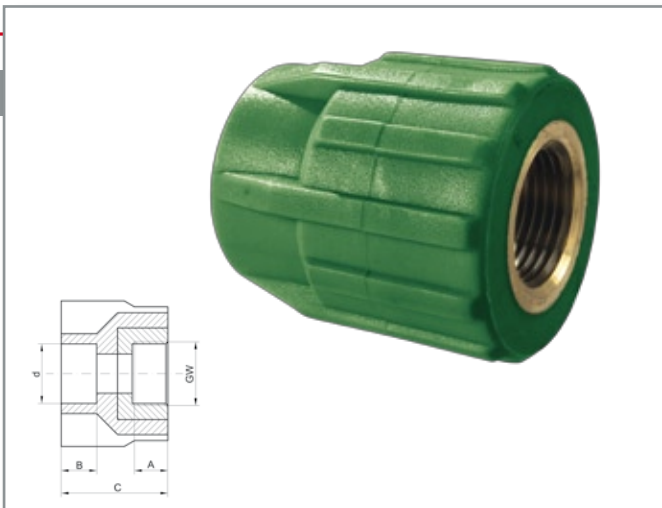

### PRIZË (FILETË FEMËRORE)

Art.no	d	GW	A	B min.	C	Pcs/pack
G60000	16	3/8"	13	13,3	42,0	100
G60001	16	1/2"	12	13,3	42,0	100
G60002	20	1/2"	12	14,5	39,5	100
G60003	20	3/4"	14	14,5	44,5	90
G60004	25	1/2"	12	16,0	46,5	100
G60005	25	3/4"	14	16,0	46,5	90

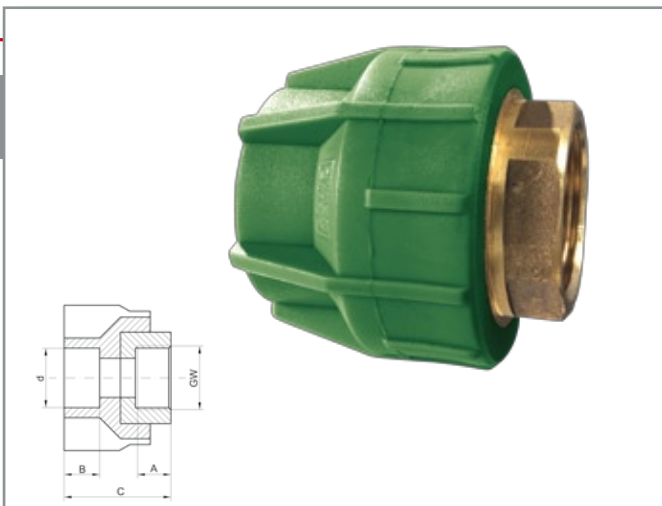

### PRIZË HEKSAGONALE (FILETË FEMËRORE)

Art.no	d	GW	A	B min.	C	Pcs/pack
G60006	32	1"	17	18,1	52,5	50
G60007	40	1 1/4"	20	20,5	66,0	40
G60008	50	1 1/2"	20	23,5	71,0	33
G60009	63	2"	24	27,4	81,5	18
G60010	75	2 1/2"	25	31,0	85,0	12
G60011	90	3"	30	35,5	102,5	6

**PRIZË (FILETË MASHKULLORE)**

Art.no	d	GZ	A	B min.	C	Pcs/ pack
G61000	16	3/8"	12	13,3	54,0	100
G61001	16	1/2"	12	13,3	54,5	100
G61002	20	1/2"	12	14,5	51,5	100
G61003	20	3/4"	17	14,5	61,5	90
G61004	25	1/2"	12	16,0	58,5	100
G61005	25	3/4"	17	16,0	63,5	90

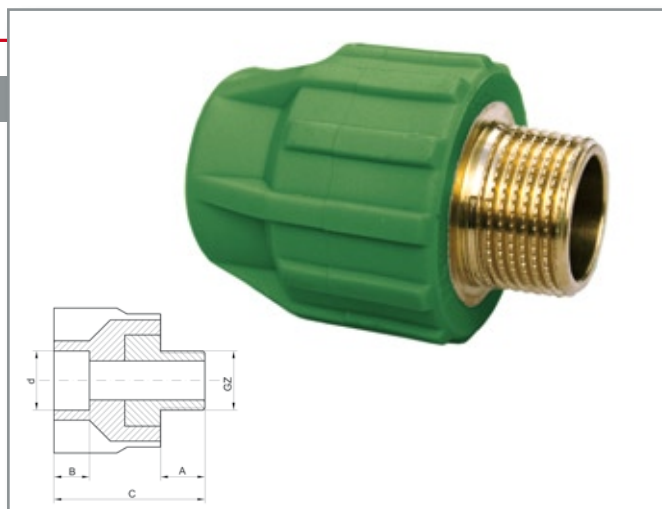

**PRIZË HEKSAGONALE  
(FILETË FEMËRORE)**

Art.no	d	GZ	A	B min.	C	Pcs/ pack
G61006	32	1"	20,0	18,1	71,5	50
G61007	40	1 1/4"	21,0	20,5	80,5	35
G61008	50	1 1/2"	21,0	23,5	96,0	36
G61009	63	2"	24,5	27,4	102,0	18
G61010	75	2 1/2"	26,5	31,0	107,0	10
G61011	90	3"	34,0	35,5	132,0	6

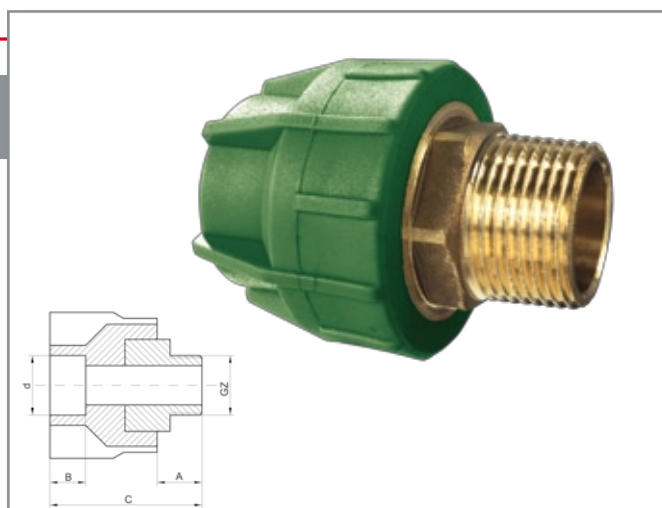

**MBIKALESË**

Art.no	D	L	Pcs/pack
G80000	16	315	200
G80001	20	315	150
G80002	25	315	100
G80003	32	315	60

**RRETH KOMPENZACIONI**

Art.no	D	L	d	Pcs/pack
G80010	16	370	182	20
G80011	20	370	190	20
G80012	25	370	200	15
G80013	32	370	214	10

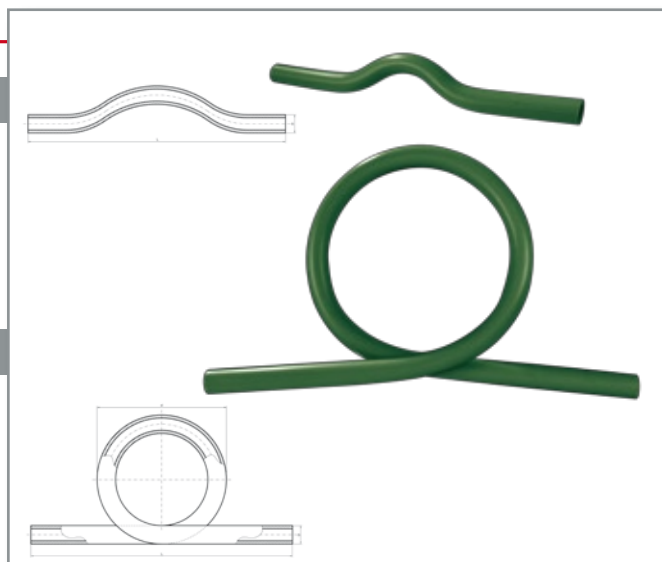

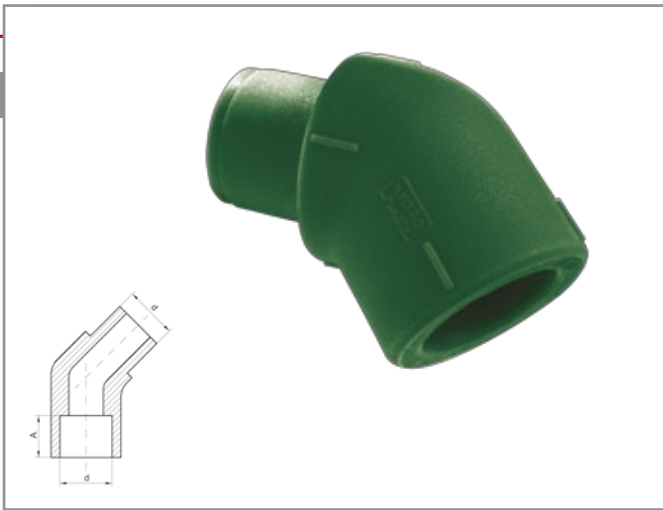

**BËRRYL 45° MF**

Art.no	d	A min	Pcs/pack
G29200	16	13,3	800
G29201	20	14,5	500
G29202	25	16	300

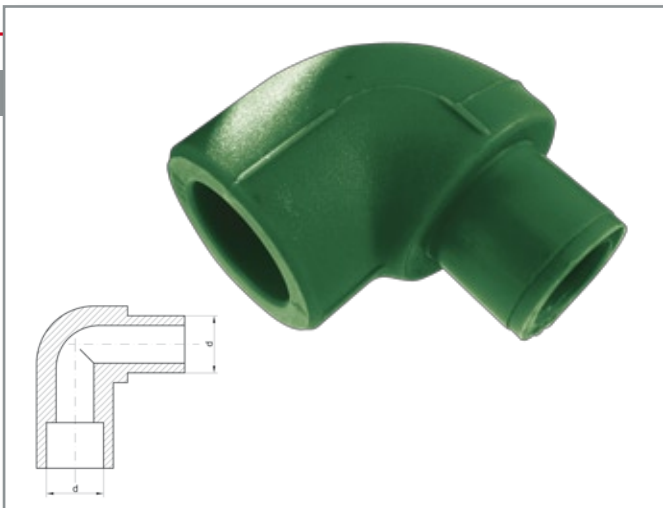

**BËRRYL 90° MF**

Art.no	d	Pcs/pack
G29100	16	800
G29101	20	500
G29102	25	300

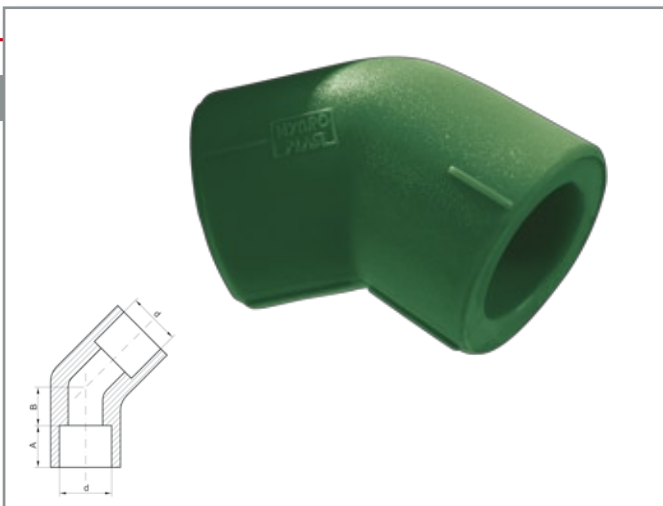

**BËRRYL 45°**

Art.no	d	A min.	B	Pcs/pack
G24500	16	13,3	6,0	800
G24501	20	14,5	6,0	500
G24502	25	16,0	7,0	300
G24503	32	18,1	9,0	160
G24504	40	20,5	11,0	100
G24505	50	23,5	13,0	50
G24506	63	27,4	17,0	30
G24507	75	31,0	18,0	15
G24508	90	35,5	21,5	12

**BËRRYL 90°**

Art.no	d	A min	B	C	Pcs/pack
G29000	16	13,3	10	37	800
G29001	20	14,5	12	42	500
G29002	25	16,0	16	51	300
G29003	32	18,1	18	60	160
G29004	40	20,5	20	69	100
G29005	50	23,5	22	89	50
G29006	63	27,4	34	106	30
G29007	75	31,0	40	122	15
G29008	90	35,5	51	147	12
G29009	110	41,5	56	167	8

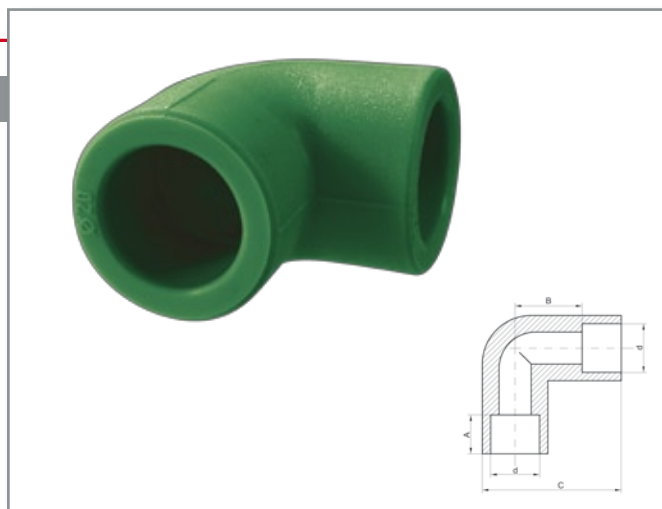

**BËRRYL (FILETË FEMËRORE)**

Art.no	d	GW	A	B min	C	E	Pcs/pack
G21000	16	1/2"	12	13,3	49	46	100
G21001	20	1/2"	12	14,5	55	51	100
G21002	20	3/4"	14	14,5	58	51	90
G21003	25	1/2"	12	16,0	56	54	100
G21004	25	3/4"	14	16,0	62	54	90
G21005	32	3/4"	14	18,1	64	58	60

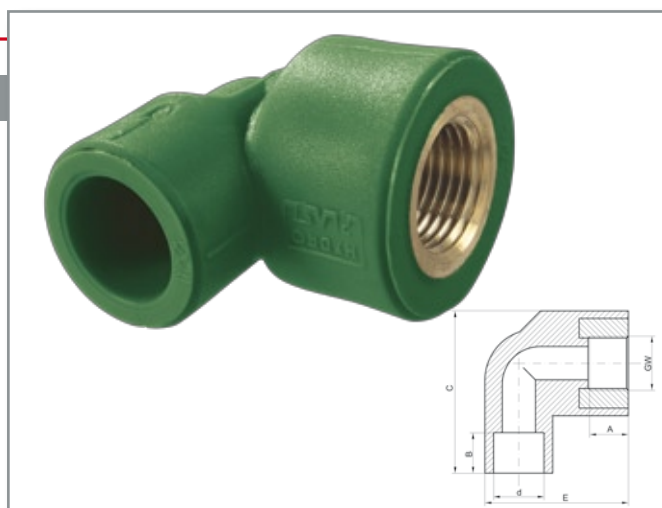

**BËRRYL (FILETË MASHKULLORE)**

Art.no	d	GZ	A	B min	C	E	Pcs/pack
G22000	16	1/2"	12	13,3	49	58	100
G22001	20	1/2"	12	14,5	55	63	100
G22002	20	3/4"	17	14,5	58	69	90
G22003	25	1/2"	12	16,0	56	66	100
G22004	25	3/4"	17	16,0	62	71	90
G22005	32	3/4"	17	18,1	64	75	60

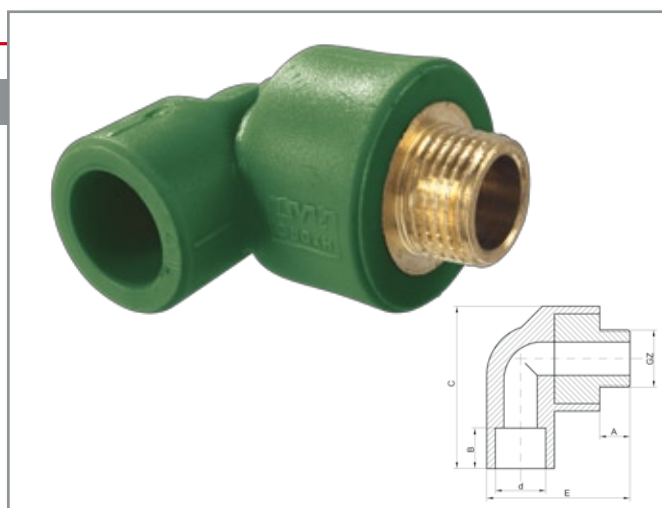

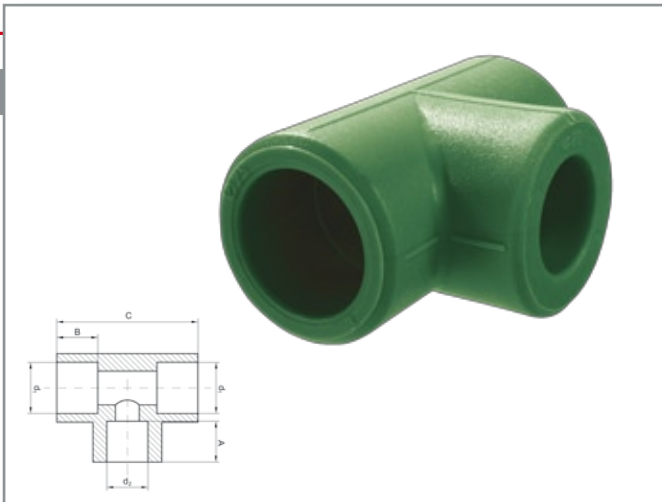

### T-PJESË E REDUKUAR

Art.no	d <sub>1</sub> /d <sub>2</sub> /d <sub>1</sub>	A min.	B min.	C	Pcs/pack
G50099	20/16/20	13,3	14,5	55,0	260
G50100	25/16/25	13,3	16,0	64,0	220
G51001	25/20/25	14,5	16,0	63,5	220
G55000	32/16/32	13,3	18,1	76,0	100
G51002	32/20/32	14,5	18,1	75,5	100
G51003	32/25/32	16,0	18,1	76,0	100
G51004	40/20/40	14,5	20,5	85,0	60
G51005	40/25/40	16,0	20,5	86,0	60
G55001	40/32/40	18,1	20,5	86,5	60
G51006	50/20/50	14,5	23,5	89,5	50
G51007	50/25/50	16,0	23,5	89,5	50
G51008	50/32/50	18,1	23,5	89,5	40
G55002	50/40/50	20,5	23,5	106,0	50
G55003	63/32/63	18,1	27,4	126,0	25
G51009	63/40/63	20,5	27,4	126,0	22
G55004	63/50/63	23,5	27,4	126,0	22
G51010	75/40/75	20,5	31,0	146,0	15
G51013	90/50/90	23,5	35,5	138,0	10
G51012	90/63/90	27,4	35,5	148,0	10
G51011	90/75/90	31,0	35,5	160,0	10

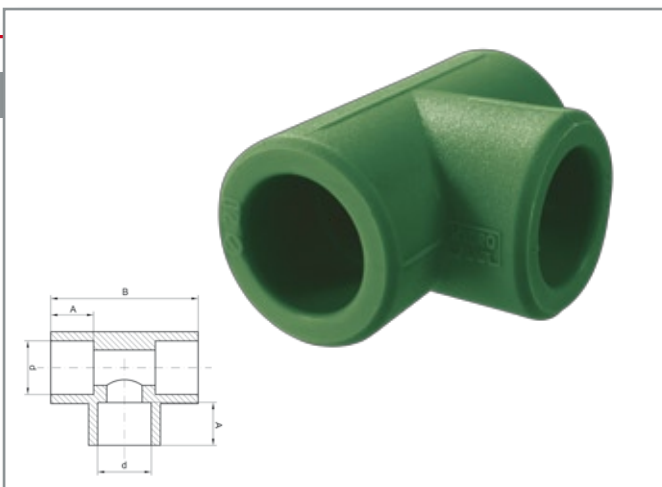

### T-PJESË

Art.no	d	A min.	B	Pcs/pack
G50000	16	13,3	48,0	480
G50001	20	14,5	54,0	320
G50002	25	16,0	63,5	220
G50003	32	18,1	75,5	100
G50004	40	20,5	87,0	60
G50005	50	23,5	106,5	50
G50006	63	27,4	126,0	22
G50007	75	31,0	146,0	15
G50008	90	35,5	173,0	10
G50009	110	41,5	186,0	6

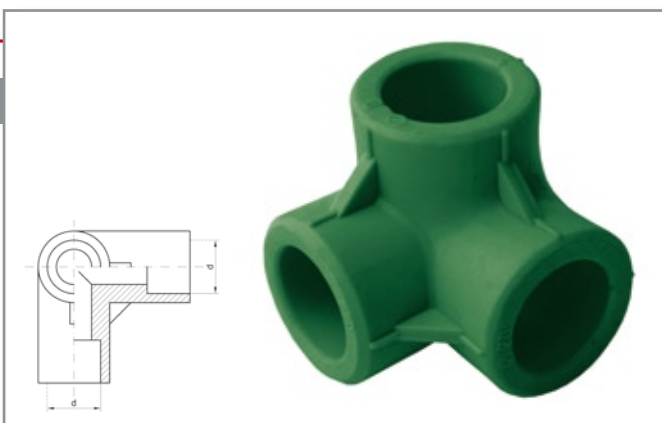

### T- PJESË KËNDORE

Art.no	d	Pcs/pack
G50050	20	360

**T-PJESË (FILETË MASHKULLORE)**

Art.no	d	GZ	A	B min.	C	E	Pcs/pack
G53001	20	½"	12	14,5	54	64,5	100

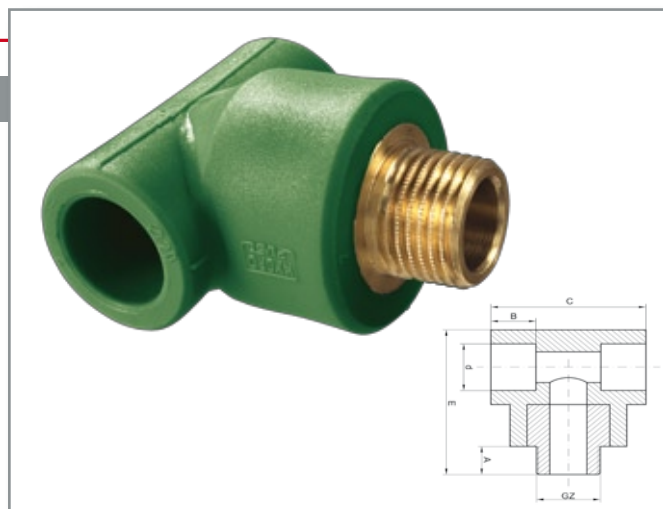

**T-PJESË (FILETË FEMËRORE)**

Art.no	d	GW	A	B min.	C	E	Pcs/pack
G52000	16	½"	12	13,3	52	46,5	100
G52001	20	½"	12	14,5	54	52,0	100
G52002	20	¾"	12	14,5	54	52,0	90
G52003	25	½"	12	16,0	76	55,0	100
G52004	25	¾"	12	16,0	76	56,0	90
G52005	32	¾"	12	18,1	80	58,0	45

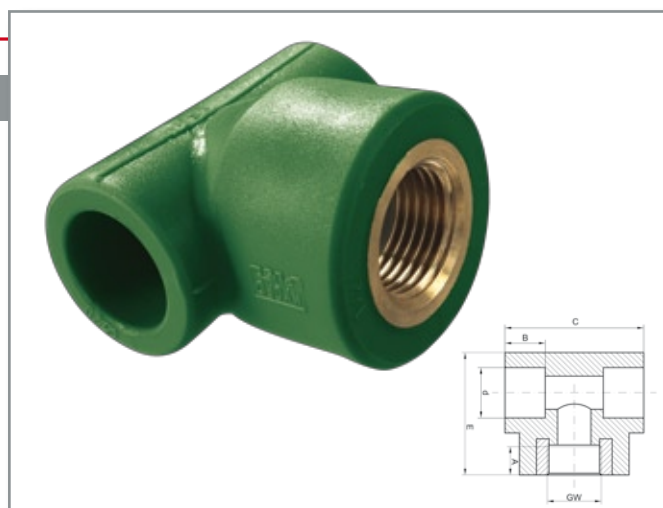

**PAJIM KATËRKËNDËSH**

Art.no	d	Pcs/pack
G54000	16	320
G54001	20	320

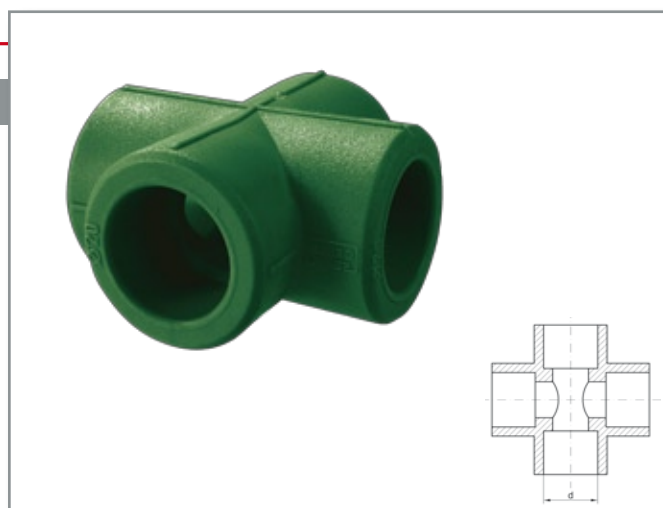

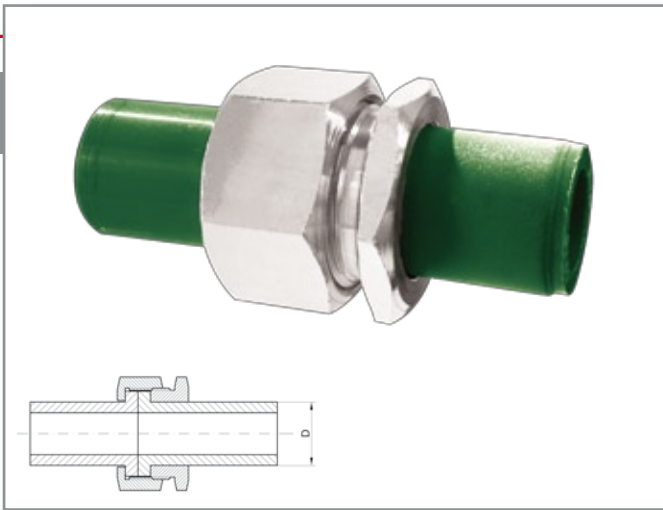

**RAKORD BASHKUES  
(PLASTIKË-PLASTIKË)**

Art.no	D	Pcs/pack
G62001	20	200

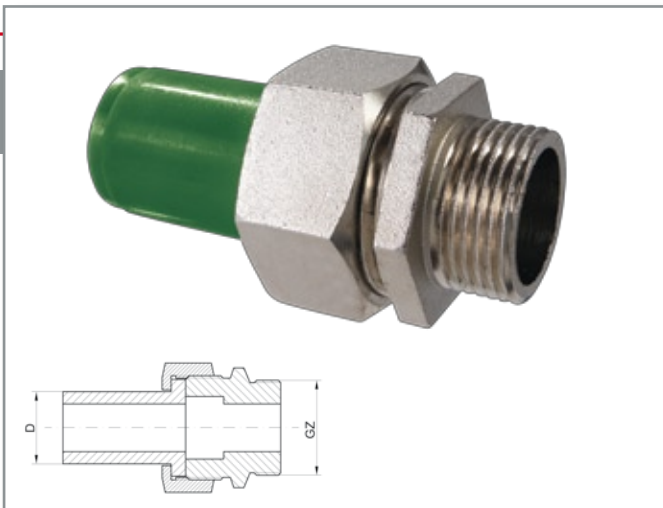

**RAKORD BASHKUES (PLASTIKË -  
METAL, FILETË MASHKULLORE)**

Art.no	D	GZ	Pcs/pack
G63000	16	½"	200
G63001	20	½"	200
G63002	20	¾"	200
G63003	25	¾"	100
G63004	25	1"	100

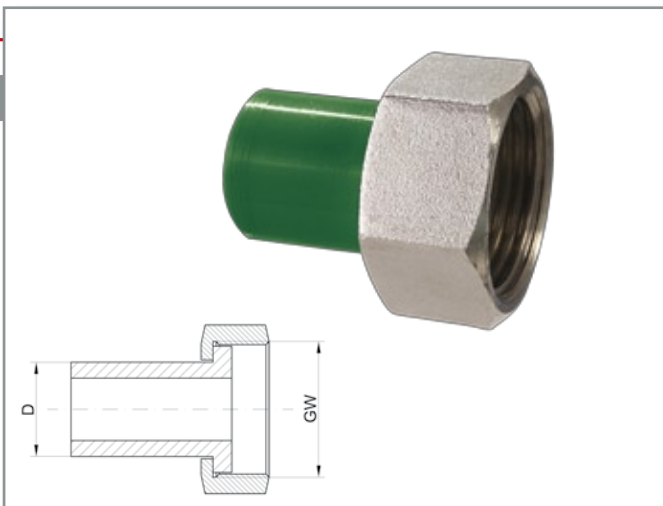

**ADAPTER ME FILETË**

Art.no	D	GW	Pcs/pack
G63500	16	¾"	300
G63501	20	¾"	400
G63502	25	1"	100

**BËRRYL FINAL ME PLLAKA**

Art.no	d	GW	A min.	B	C	E	F	Pcs/pack
G23000	16	1/2"	13,3	12	50,0	47	48	100
G23001	20	1/2"	14,5	12	48,0	47	50	100
G23002	25	1/2"	16,0	12	53,5	47	55	100

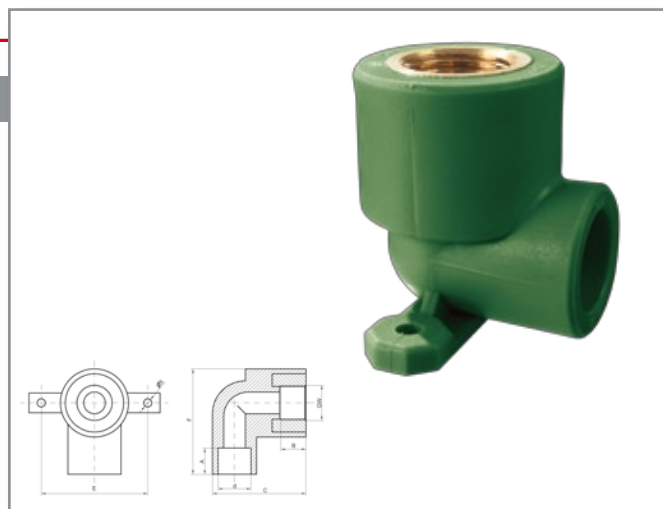

**VALVOL SFERIK**

Art.no	d
G90000	16
G90001	20

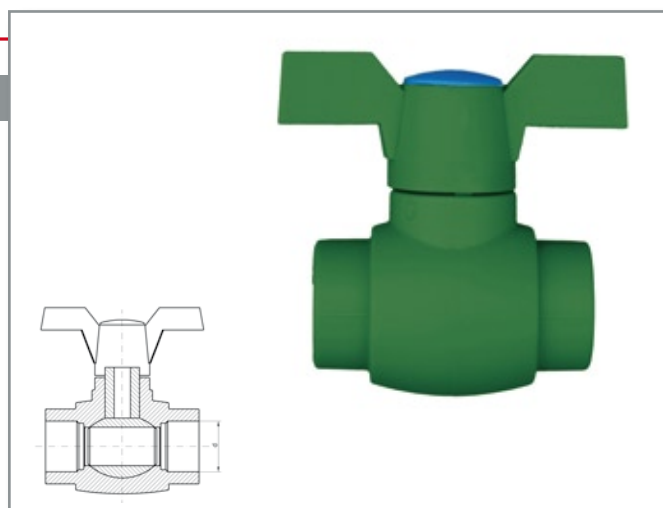

**VALVOL SFERIK**

Art.no	d
G90002	25
G90003	32
G90004	40
G90005	50
G90006	63
G90007	75

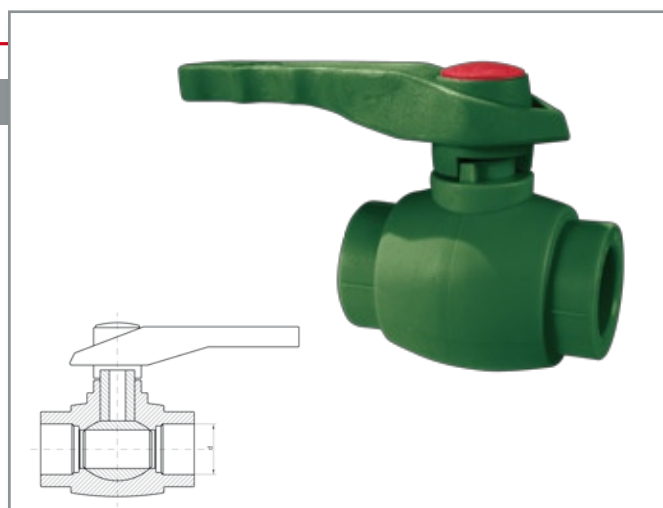

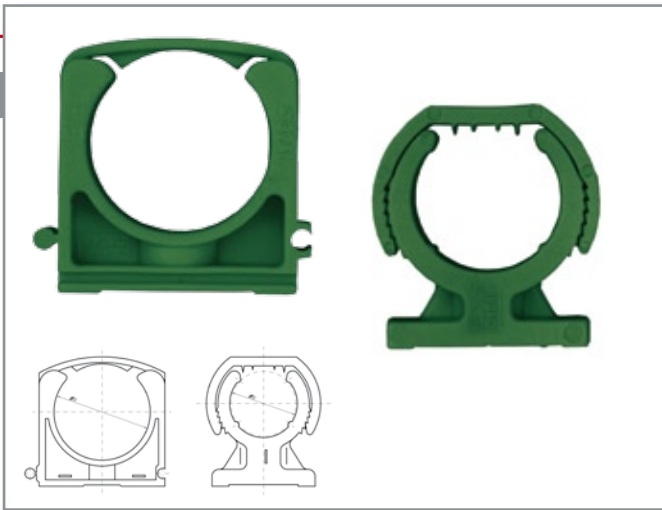

### SHTRËNGESA PËR TUBA

Art.no	Art.no for stabi pipes	D	Pcs/pack
G81000	G82000	16	1000
G81001	G82001	20	800
G81002	G82002	25	600
G81003	G82003	32	400
G81004	G82004	40	240
G81005	G82005	50	200
G81006		63	120
G81007		75	80
G81008		90	80

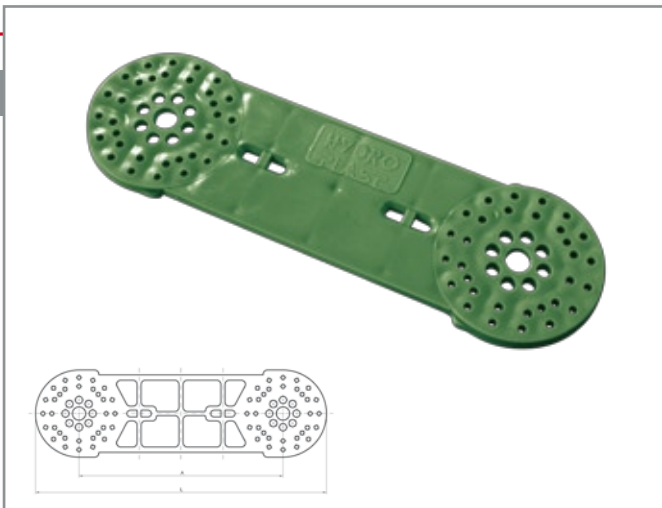

### PLLAKË PËR PAJIME

Art.no	A	L	Pcs/pack
G81101	149	213	150

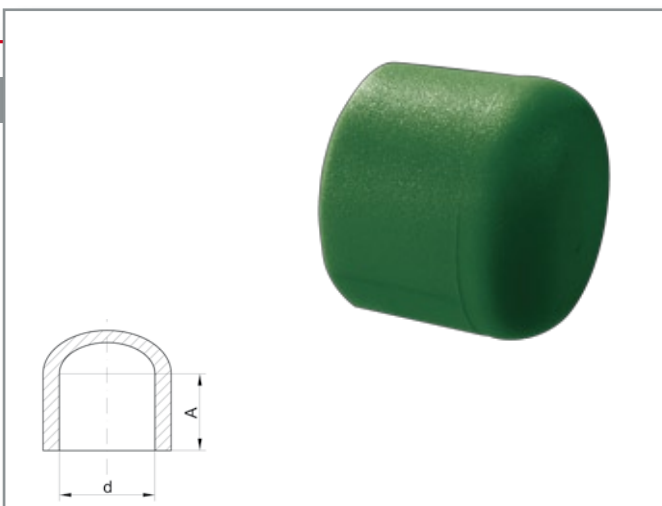

### KAPELË

Art.no	d	A min.	Pcs/pack
G70000	16	13,3	1000
G70001	20	14,5	1000
G70002	25	16,0	600
G70003	32	18,1	400
G70004	40	20,5	200
G70005	50	23,5	150
G70006	63	27,4	60
G70007	75	31,0	45
G70008	90	35,5	30
G70009	110	41,5	24

**REDUKTOR MF**

Art.no	D/d	A	B min.	C	Pcs/pack
G40000	20/16	16,0	13,3	34,0	800
G40001	25/16	18,5	13,3	36,0	700
G40002	25/20	18,0	14,5	37,0	700
G40003	32/20	21,0	14,5	42,0	400
G40004	32/25	21,0	16,0	43,5	400
G40005	40/20	26,0	14,5	50,0	300
G40006	40/25	26,0	16,0	50,0	300
G40007	40/32	26,0	18,1	50,5	200
G40008	50/32	33,0	18,1	56,5	120
G40009	50/40	32,0	20,5	60,0	120
G41000	63/32	41,0	18,1	65,0	100
G40010	63/40	41,0	20,5	66,5	100
G40011	63/50	35,0	23,5	63,0	100
G40012	75/50	37,5	23,5	65,5	40
G40013	75/63	34,5	27,4	81,0	40
G40014	90/50	37,5	23,5	71,0	48
G40015	90/63	37,5	27,4	73,0	45
G40016	90/75	36,5	31,0	75,0	45
G40017	110/90	38,5	35,5	76,0	25

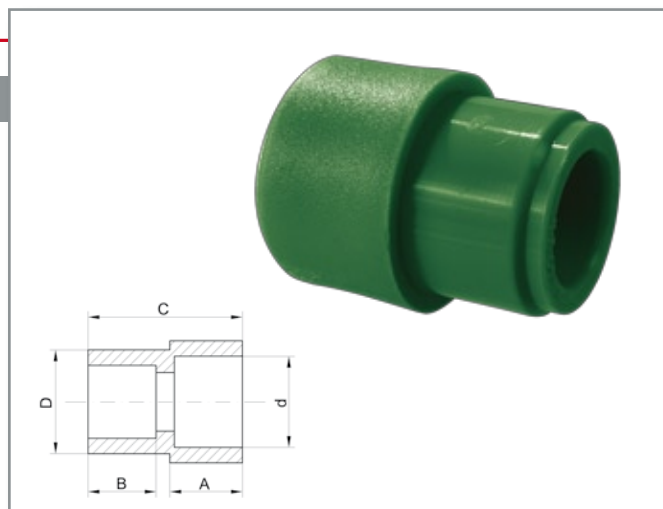

**GRYKËZ 110**

Art.no	d	A	Pcs/pack
G80501	with groove 110	85	16
G80502	without groove 110	79	16

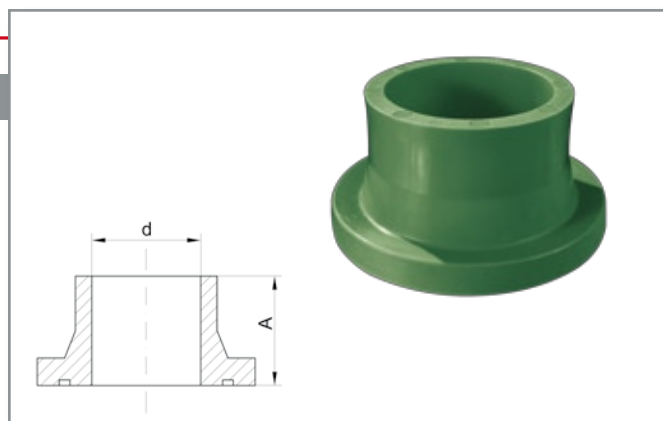

**PRERËSE PËR TUBA**

Art.no	For pipe in diameter	
10085001	0-40	VIRAX
10085002	50-110	REMS
10085003	extra knives for 10085002	50-110





### PRERËSE PËR STABI

Art.no	For pipes with diameter	
85000	Stabi-Shaver	16/20
85001	Stabi-Shaver	20/25
85002	Stabi-Shaver	25/32
85003	Stabi-Shaver	32/40
85009	Stabi-Shaver heavy	40
85004	Stabi-Shaver heavy	50
85005	Stabi-Shaver heavy	63
85006	Stabi-Shaver heavy	75
85007	Stabi-Shaver heavy	90
85008	Stabi-Shaver heavy	110
85010	Stabi-Shaver for drill	16
85011	Stabi-Shaver for drill	20
85012	Stabi-Shaver for drill	25
85013	Stabi-Shaver for drill	32



### APARAT PËR SALDIM

Art.no	Power	
10085011	welding machine	700 W
10085012	welding machine	1300 W
10085015	welding machine	1800 W
85060	complet (700W + box + statief + 2 screws + Ø16-32)	
85061	complet (700 W + box + statief + 2 screws + Ø16-50)	
85070	complet (1300W + box + statief + 2 screws + Ø16-32)	
87071	complet (1300 W + box + statief + 2 screws + Ø16-50)	
85080	complet (1800 W + box + statief + 2 screws + Ø16-50)	
85010	case	
85020	stand	
85030	screws for welding endings	



### APARAT PËR PËRFUNDIMIN E SALDIMIT

Art.no	For pipes with diameter	
84000	welder ending	16
84001	welder ending	20
84002	welder ending	25
84003	welder ending	32
84004	welder ending	40
84005	welder ending	50
84006	welder ending	63
84007	welder ending	75
84008	welder ending	90
84009	welder ending	110





## PRODHUES EVROPIAN I PP-R SISTEMEVE

Hydro-Plast GERMANY  
Brüsseler Straße 2  
53842 Troisdorf-Spich  
GERMANY

Tel. +49 (0)2241-234 08-0  
Fax +49 (0)2241-234 08-21

Hydro-Plast POLAND  
Wiejska Str. 3A  
05-552 ŁAZY  
POLAND

Tel. +48 (0)22 757-98-08  
Tel. +48 (0)22 797-45-62  
Fax +48 (0)22 757-77-30

